



Mincon Group plc
Smithstown Industrial Estate
Shannon, Co. Clare, Ireland.
Tel: +353 (61) 361099
sales@mincon.com
www.mincon.com

© 2020 Mincon Group plc, All Rights Reserved. The information contained within this document is subject to change without notice.



MINCON HDD Drilling Range

MINCON HDD Pullreamer Range



The Driller's Choice

www.mincon.com

The Mincon HDD Story

In 2002 Mincon, in collaboration with leading industry professionals, started design and manufacturing of a range of pneumatically powered horizontal directional drilling systems to service the trenchless utility industry. Since then the tools have become the benchmark for steerable drilling systems in medium to hard rock where conventional directional drilling systems struggle.

The Mincon Hard Rock Range offers the most complete line of steerable hammer systems on the market, covering pilot holes from 3 1/2" (89mm) to 9 1/4" (235mm) the tools can be used on mini class HDD machines to large Pipeline Class machines. With the Mincon Hard Rock Support Station and hoses any conventional HDD machine can be converted for rock drilling. The sonde carriage can be easily adapted to your existing locating equipment.

Utilizing "High Frequency Cycle" technology Mincon hammer systems provide many benefits to the contractor. Small chip production and faster material removal from the bit face keeps the bore hole cleaner and reduces the possibility of getting stuck. With less vibration to the drill string you ensure less wear and tear to the rig and locating sonde. Steering capabilities are greatly improved and in head to head tests against other competitor manufacturers the Mincon Hard Rock systems out steered in dirt, cobble and solid rock.

Mincon offers the revolutionary Pull Reamer system. Once the pilot hole has been drilled, the pilot hammer and sonde is removed and the Mincon Pull Reamer is attached to the drill string. The Pull Reamer is then drawn back towards the drill machine and the system is capable of hammer reaming from 7" (178mm) to a maximum of 14" (356mm). This innovative reaming method is the fastest way to ream a rock bore and is vastly superior to conventional methods in all rock conditions.

The philosophy at Mincon is to provide world-class products, training, service and support. We like to think that we are with you from beginning to end. The Mincon Hard Rock Horizontal Directional Drilling Range are the only systems available that can offer the contractor the peace of mind that comes with superior performance, reliability, innovation and complete support. Be wary of imitators that promise the world but just can't deliver.

Mincon HDD Pull Reamer Features

The Mincon range of HDD Pull Reamer Hammers is the only pneumatic hammers being employed in the HDD industry and is designed around proven technology and redefines the performance scale when compared to other conventional HDD reaming tools on the market. While providing the most complete range of pilot hammers, Mincon also provides their world class design and technology including:

- Patented reverse air flow hammer cycle allows for pull reaming of a pilot bore of 3-1/2" (89mm) out to 7-8" (178-203mm) and 4-1/4" (108mm) out to 9" (229mm) and pull reaming of a pilot bore of 5 1/4" (133mm) out to 10-12" (254-305mm) and 6 1/4" (159mm) out to 14" (356mm) on the HDD80PR.
- A range of bits are offered with different grades of standard carbide and diamond enhanced carbide to maximize bit life in every drilling condition.
- High pressure/high volume compressed air powers reaming operations and requires minimal torque and feed pressure loads on drill machine increasing overall life of drill.
- Attachments can be used to pull utilities as the hole is reamed.
- Water injection system delivers compressed air mixed with a water/polymer/foam (0-5 gal/min) and rock drill oil (2-4 pints/min) to operate the drilling cycle. This results in minimal, environmentally friendly cleanup. This solution can be used in environmentally sensitive locations using Mincon's Envirosafe RDO, a biodegradable rock drilling oil.



S P E C I F I C A T I O N S

Mincon HDD Hammer Model		Mincon HDD70PR				Mincon HDD80PR			
Drill Bit Shank Type		HDD70PR				HDD80PR			
Hammer Outside Diameter	Metric	165mm				230mm			
	Imperial	6.5"				9.06"			
Hammer Length (Less Drill Bit)	Metric	1301mm				1550mm			
	Imperial	51.2"				61"			
Backhead Spanner (Flat Size)	Metric	150mm				171.5mm			
	Imperial	5.91"				6.75"			
Pilot Bit Size	Metric	89mm	108mm	133mm	133mm	159mm	184mm	235mm	305mm
	Imperial	3.5"	4.25"	5.25"	5.25"	6.25"	7.25"	9.25"	12"
Reamer Bit Size	Metric	178-203	178-229	178-229	254-305	254-356	254-356	356-406	406mm
	Imperial	7"-8"	7"-9"	7"-9"	10"-12"	10"-14"	10"-14"	12"-16"	16"
Rod Adapter OD	Metric	83mm	102mm	127mm	127mm	127mm	153mm	222mm	273mm
	Imperial	3.25"	4"	5"	5"	5"	6"	8.75"	10.75"
Rod Adapter Thread	API Reg Pin	2 3/8" API R.P	2 7/8" API R.P	3 1/2" API R.P	3 1/2" API R.P	3 1/2" API R.P	3 1/2" API R.P	3 1/2" API R.P	3 1/2" API R.P
Backhead Thread	API Reg Pin	3 1/2" API Reg Pin				3 1/2" API Reg Pin			
Hammer Weight Less Bit	Metric	130kg				184.5kg			
	Imperial	301 lbs				406 lbs			
Piston Weight	Metric	15.9kg				26.3kg			
	Imperial	35 lbs				58 lbs			
Recommended Min Air Less 250ft	Metric	1529m ³ @ 24.1 bar				1529m ³ @ 24.1 bar			
	Imperial	900cfm @ 350psi				900cfm @ 350psi			
Recommended Min Over 250ft	Metric	2125m ³ @ 24.1 bar				2125m ³ @ 24.1 bar			
	Imperial	1250cfm @ 350psi				1250cfm @ 350psi			

¹ Drilling conditions and project specifications may require larger air package to be used. Maximum operating pressure of 500 psi

ROD ADAPTOR SIZING

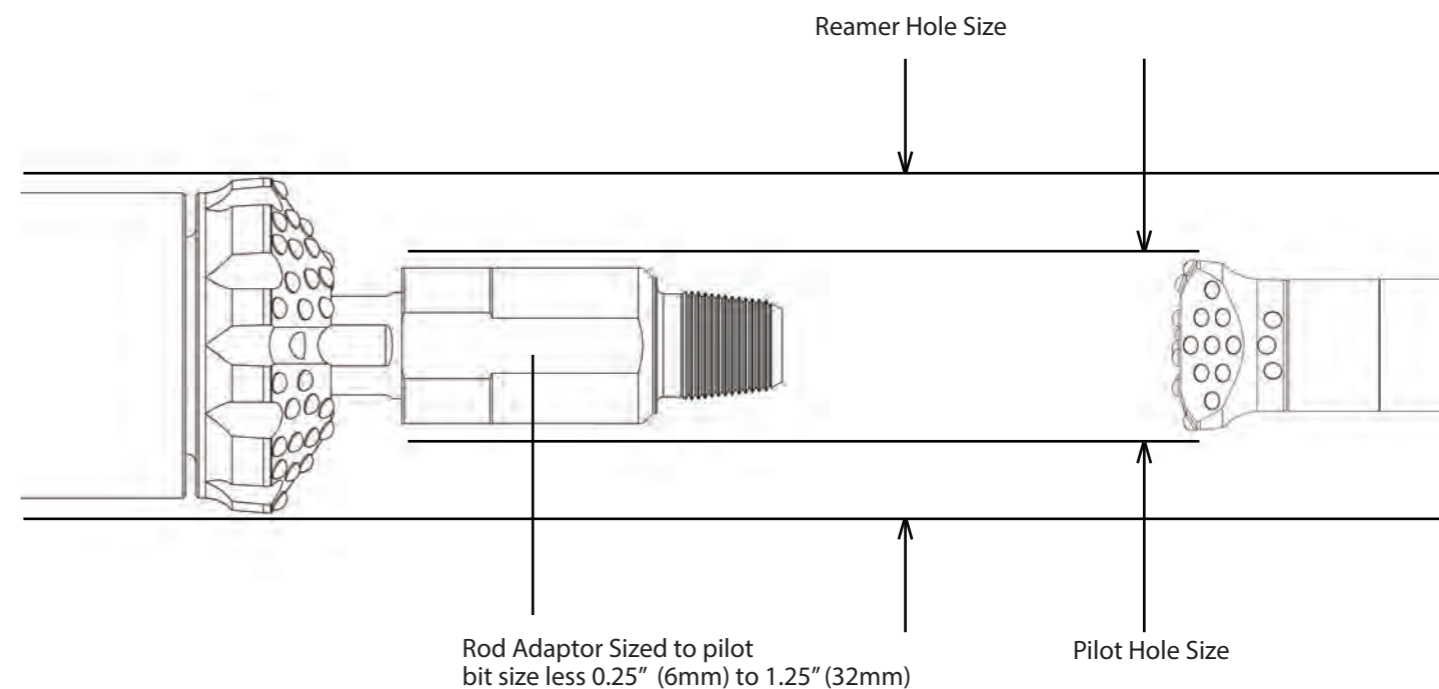

The Driller's Choice

www.mincon.com